



Available online at
<https://jurnalteknik.unisla.ac.id/index.php/CVL>

 <https://doi.org/10.30736/cvl.v2i2>



Upper Structure of Precast Concretes Comparison: PC-I and PC-U in West Outer Ring Road

Jaka Propika¹, Yanisfa Septiarsilia², Eka Susanti³, Heri Istiono⁴

Civil Engineering, Adhi Tama Institute of Technology

Email : ¹jakapropika@itats.ac.id, ²yanisfa.septi@itats.ac.id

³ekasusanti@itats.ac.id, ⁴heri_istiono@itats.ac.id

ARTICLE INFO

Article History :

Article entry :2022-06-08

Article revised :2022-08-08

Article received :2022-08-31

Keywords :

Girder, Prestressed, Precast Concrete-I, Precast Concrete-U, Flyover

IEEE Style in citing this article :

J. Propika, Y. Septiarsilia, E. Susanti dan H. Istiono, "Upper Structure of Precast Concretes Comparison: PC-I and PC-U in West Outer Ring Road," CIVILA, vol. 7, no. 2, pp. 149-160, 2022.

ABSTRACT

Increasing of motorcycle numbers in big cities in Indonesia, especially in Surabaya. The traffic becomes crowded and road capacity is exceeded. Because of the increasing of motorcycle volume, especially in western part of Surabaya, the government built a flyover in west outer ring road to provide solution to congestion in Surabaya. This study aimed to determine the comparison between PC-I girder and PC-U girder used. In west outer ring road, the method was used to calculate prestressed beam was fully prestressed. The researcher reviewed the prestressed beam from behavior, reaction, and impact to the all of bridge structures from structure. The Software SAP 2000 V.14.2.5 is used to structure calculation analysis. According to analysis result, the calculation has been carried out, the difference ratio of the bridge floor slabs was studied. Flyover model with PC-U prestressed beam had smaller ratio than PC-I. The comparison of strand used in PC-U beams was more than PC-I with 42.22%. The maximum moment value was occurred in PC-I girder beam was 1541.979 Tons.meter and PC-U girder was 2252.599 Tons.meter. The strand requirements and cross area section was compared too.



Copyright © 2022 Jaka Propika, dkk. This work is licensed under a [Creative Commons Attribution-ShareAlike 4.0 International License](https://creativecommons.org/licenses/by-sa/4.0/). Allows readers to read, download, copy, distribute, print, search, or link to the full texts of its articles and allow readers to use them for any other lawful purpose.

1. Introduction

The increase in the volume of motorized vehicles has an impact on traffic congestion and the road capacity is exceeded. Traffic congestion occurs because the vehicle speed is too slow and does not match the planned speed, causing heavy traffic [1]. The increase in the volume of motorized vehicles also causes congestion in West Surabaya. To reduce congestion in West Surabaya, the government built a flyover on the west outer ring road. The fly over structure is the same as the bridge structure, consisting of an upper and lower structure. The upper structure consists of a floor structure, girders and diaphragms [2]. The structure of flyover is same as the bridge. The Bridge is one of the infrastructure buildings that industrial, economic, and social growth of a region [3]. The bridge is structure that joints two or more points which are separated by rivers, valleys, and others [2]. Precast concrete elements, such as bridge girders, have been used successfully in bridge construction for many years. These elements have adapted to challenging and continuously evolving requirements related to serviceability and constructability [4]. A bridge structure is divided into two parts, upper structure and lower structure. The upper structure consists of pavement, traffic deck, diaphragm, and girder, the lower structure consists of abutment, pillar, bearing, and foundation. Bridge structure has variety of type, based on its material and system. This study aimed to compare PC-I Girder and PC-U Girder of Upper Structure. The PC-U girder is an attractive alternative to the I-girders [5].

There are many types of prestressed concrete girders including PC I Girder, PC U Girder, Box Girder and the Voided Slab. Each type has its own advantages and disadvantages [4]. Girder is the main beam on the bridge/fly over. The use of precast concrete as a girder has been used in many bridges because of its better quality and practical use. There are 2 precast concrete girder shapes, namely I shape (Precast Concrete I-PC-I) and U shape (Precast Concrete U-PC-U). The PC-I girder has a sleek design and is proven to be sturdy. The taller and slimmer the PC-I girder is, the more vulnerable it is against torsion. The development of the PC-U girder is attempted to overcome the occurrence of torsion. PC-U girder has an area of larger area than the PC-I girder, so that it affects the increase in the volume and weight of the superstructure. However, the PC-U girder can reach the maximum distance between the girders, almost 2 times longer than the PC-I girder, meaning that more girders are needed when using PC-I girders. In addition, the PC-U girder has a maximum span length that is 1.2 times shorter than the PC-I girder [6]. Upper Structure of West Outer Ring Road Flyover uses Precast I Section Girder. PC-I Girder has slim form and proved sturdy, therefore PC-I Girder is used until now. However, using PC-I Girder which has slim form and high caused torsion. Over time, reinforced concrete bridge structures, especially girders, were developed so that various models or girder forms emerged. PC-U Girder is one of girder form. Girder has function as a support for vehicle load which distributed to lower structure, such as abutment, pillar, bearing and foundation. The using of PC-U is still rarely found on precast concrete bridge system in Surabaya. PC-U has a larger cross section than PC-I. This has an impact on the overall weight of a precast reinforced concrete bridge structure. With different shape and area section both of PC-I and PC-U girder, the behavior of element also different. Beside, PC-U has longer maximum distance between girder than PC-I, PC-I Girder has maximum distance between girder 1,85 meters and PC-U 3,1 meters. The PC-I has a maximum span of 50 meters while the PC-U is only 40 meters. From this study, the result will be as reference in using PC-I and PC-U Girder of precast structure design.

Literature Review

Flyover is a structure which carries one road over the top of another road to manage the traffic. Flyover structure is planned with bridge code [7] and urban geometry road standart [8]. Several previous studies have compared the use of PC-I and PC-U girders. Among them

are [3] which compares the use of PC-I and PC-U girders on the Wonogiri Gorge Bridge. The results showed that the number of PC-U girders needed was less than that of PC-I girders. In addition, the tendon, moment, and shear reinforcement in the PC-U Girder bridge is more than that of the PC-I Girder bridge. Another study, conducted by [6], compared the use of PC-I and PC-U girders on the Marthadinata Bogor Flyover. The results showed that the use of PC-I girders was 18% more cost-effective than PC-U girders. [9] also conducted research on the use of PC-I and PC-U girders on the Mahakan Samarinda IV Bridge. The results showed that the loss of prestressing force on the PC-I girder was 14% more than the PC-U girder. By considering the total value of prestressing loss, number of girders, girder height, and overturning forces that occur in PC-I and PC-U girders, the use of PC-U girders is considered much safer, economical and efficient. In 2019, [10] was compared PC-U type and PC-V type. The results showed that using PC-V type girder gains the benefit of efficiency in terms of both cost and time, this is showed by the percentage of production PC-V girder is 97% faster than PC-I girder. [11] compared PC-I and Box Girder due to stiffness and deflection, the result percentage of loss of prestressed PC-I was higher than box girder, while deflection of box girder was higher than PC-I. [12] was conducted research PC-U Girder due to vertical bearing capacity and damaged web can lead to failure structure, furthermore [13] analyze the PC I girder design used on the bridge, impact of load combination due to behavior. In 2018 [14] proposed PC-T girder which is optimized prestressing layout and reduce conventional reinforcement and combined with steel fibers. Two large scale spliced I-Girder specimens and CIP as part research program aim to evaluated the shear strength and behavior [15].

Based on the results of previous studies, there are many factors in determining the use of the two types of girders. In this study, a comparison of the use of PC-U and PC-I girder reviews all aspects reviewed by previous researchers by adding a review of their effect on pile requirements.

a. Design Criteria

Pre-stressed concrete is basically concrete in which internal stresses of a suitable magnitude. In reinforced concrete members, the pre-stress is commonly introduced by tensioning the steel reinforcement [16]. Prestressed concrete structures the approach to design takes the form of cost optimization problem because different materials are involved [17]. The function of prestressing is to place the concrete structure under compression in those regions where load causes tensile stress [18]. The proposed PCI-girder is selected from the manufacturer's brochure based on the span length. The length of the flyover span is 40m, so the height of the PC I girder is 210cm. The compressive strength of concrete, $f_c' = 50$ MPa. Elastic modulus of concrete, $= 4700 \sqrt{f_c'} = 338893,94$ kg/cm², Poisson's number, $\nu = 0,20$, Shear modulus, $G = E_c / [2 * (1 + \nu)] = 13848$ MPa, Coefficient of long expansion for concrete, $\alpha = 0,00001 / ^\circ\text{C}$, Distance between girders (beam spacing) = 150 cm.

b. Precast Concrete Analysis

There are two methods of prestressing, pre tension and post tension. Pre tension method is apply prestressed to steel strands before casting concrete, whereas post tension is apply prestress to steel tendons after casting concrete. Because the strength of concrete is very dependent on the level of tension or the magnitude of the prestressing force, there are two terms in prestressing, namely fully prestressed and partially prestressed. For fully prestressed concrete structural members, the structure is designed to prevent cracking at service loads, so the fully prestressed concrete structural components are determined to determine the tensile stress that occurs. In planning a prestressed concrete bridge structure, the loss of prestressed force must be considered, because the stress on the prestressed concrete tendon decreases continuously over time [19].

Loss of prestress is a reduction in the force that occurs on the tendon when it is loaded. Loss of prestress is divided to:

1. Short term loss of prestress.
2. Loss of prestress due to influence time.

2. Research Method

The method used in loading analysis and structural performance on the west outer ring road flyover with PC-I and PC-U beam girder reinforcement using SAP 2000 program. The research steps are:

1. Collection of literature studies and previous research.
Literature review from books, building code, scholarly articles, and any other sources relevant to this study.
2. Secondary data collection includes plan data, soil data and others.
There is two kinds of plan data, primary data (shop drawing) and secondary data (soil data).

Primary data:

Name of bridge : West Outer Ring Road Flyover
 Location : Teluk Lamong, Surabaya
 Type of Structure : Prestressed concrete
 Total Length : 40 m
 Width : 10,35 m
 Road Class : II

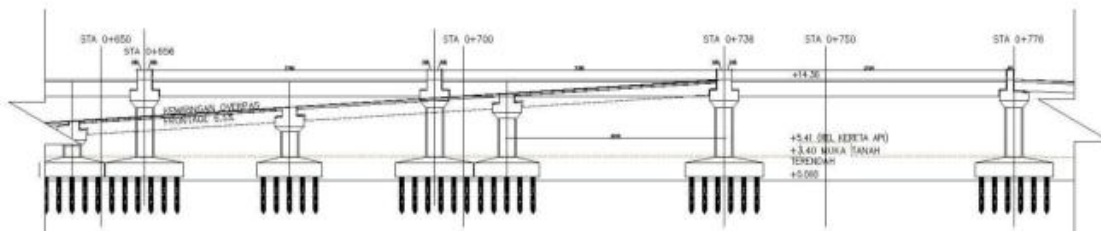

Figure 1. Long Section of West Outer Ring Road Flyover

3. Determine the dimension of both Girder (PC-I and PC-U).

Table 1. Specific Data of Girder

Specific	PC-I	PC-U
Deck thickness (ts)	25 cm	25 cm
Asphalt thickness (ta)	10 cm	10 cm
Rainwater thickness	10 cm	10 cm
Spacing of girder	1,5 m	1,41 m
Compressive strength of concrete(f_c)	35 MPa	35 MPa
Yield strength of steel (f_y)	420 MPa	420 MPa
Elastic Modulus (E_c)= $4700\sqrt{f_c}$	27805,6 MPa	27805,6 MPa
Unit weight of concrete	25 kN/m ³	25 kN/m ³
Unit weight of asphalt	22 kN/m ³	22 kN/m ³
Unit weight of rainwater	9,8 kN/m ³	9,8 kN/m ³
Span (L)	40 m	40 m

Source : *Processed Data (2022).*

Table 1 above shows specific data of both PC-I girder and PC-U girder, about dimension, material properties, and load.

PC-I Girder

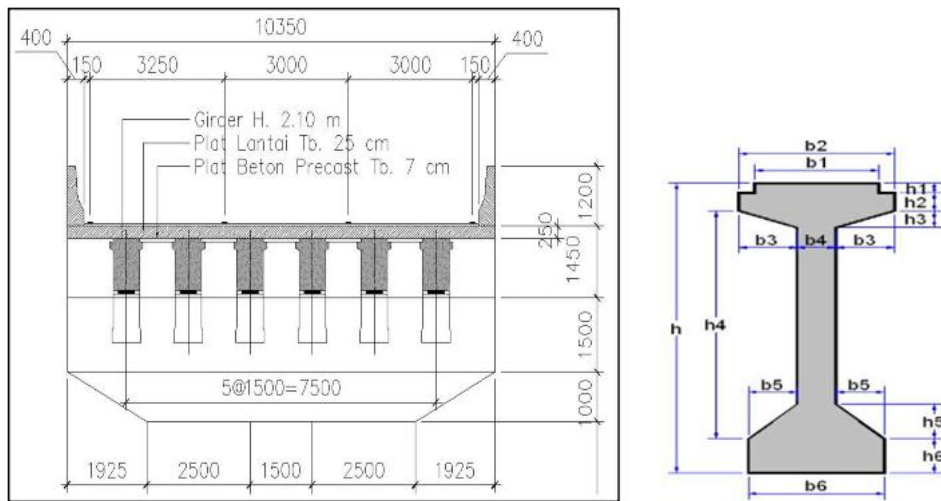

Figure 2. Cross Section of West Outer Ring Road Flyover with PC-I Girder

Accordinging Figure 2, cross section using PC-I Girder type H-210 can be seen that with a total width of 10.35 meters, 6 PC-I girders are needed, the distance each of girder is 1.5 meters.

PC-U Girder

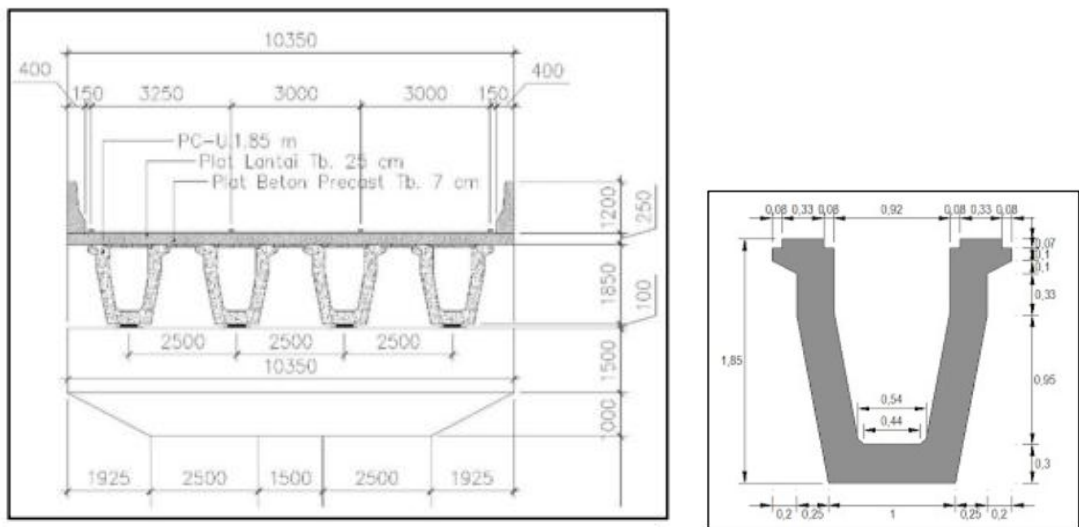

Figure 3. Cross Section of West Outer Ring Road Flyover with PC-U Girder

Accordinging Figure 3, cross section using PC-U Girder type H-185 can be seen that with a total width of 10.35 meters, 4 PC-U girders are needed, the distance each of girder is 2.5 meters.

4. Load Analysis.

Bridge loading is carried out by giving a load to the upper structure which is calculated from the total factored force and the load combination refers to SNI 1725:2016. [20] [14]

Girder Beam Loading Analysis

- a. Self-loading of girder beams.
- b. Diaphragm Weight (thickness = 0.20 m, Width = 1.30 m Height = 1.65 m), 5 pcs diaphragm (weight one diaphragm = 1.030 tons)
- c. Weight of Girder Beam (Girder length = 40m, girder specific gravity = 2.5 ton/m³)
- Weight of floor slabs (thickness=0.07m, width=0.86m, length=40m)
- d. Additional dead load, Asphalt layer + overlay (thickness=0,07m , width=0,86m , length=40m, density = 22 kN/m³)
- e. Line Load, line load "D" which consists of distributed load (BTR), that combine with line load (BGT). The load factor of D lane load is accordance with table 2.7 [7].
- f. Truck Load, considering the weight of semi trailer truck wheels against the contact area on the floor surface. The value is according to table 2.8 SNI a725-2016.
- g. Brake force is assumed to work at 1.8m above flyover floor surface. The amount of brake force (HTB) depends on the total length of the bridge (L), HTB value = 250kN (L ≤ 80m), HTB = 250+2.5(L-80) kN (80 < L ≤ 180m) and HTB = 500kN (L > 180m).
- h. Wind Load, the wind load is assumed to be a continuous pressure of 1.46 kN/m which works to press the truck from the side at a height of h/2 (h= truck height)
- i. Earthquake load, the type of soil at the flyover location is soft soil with soil parameter values obtained from http://puskim.pu.go.id/Application/design_spektra_indonesia_2011/. According to SNI 2833:2016 and SNI 1726:2019 The earthquake load parameters are PGA = 0.325, S_s = 0.663, S₁ = 0.249 F_{pga} = 1.126, F_a = 1.375, F_v = 3.005, A_s = 0.36595, SDS = 0.91163, SD₁ = 0,74825, T₀ = 0.16416, T_s = 0.82078.
- j. design criteria of strand cable, Strand yield stress (f_{py}) = 1,674 Mpa, Strand tensile strength (f_{pu}) = 1,860 Mpa, D= 12,7 mm.

According to [7] design criteria and load combination for bridge construction is reviewed to the properties and possibilities of each load. The combination of extreme loads determined at each limit state is as follows:

- Kuat I : Calculation of the combined loading obtained from the forces arising from the bridge under normal conditions without being affected by wind loads. In the calculation of strength I, the nominal force that occurs is multiplied by the load factor.
 - Kuat II : Combination of loads that depend on the use of bridges to withstand special vehicle loads without calculating wind loads.
 - Kuat III : The combination of loading is subject to wind loads with speeds between 90-126 km/hour.
 - Kuat IV : Combination of loading that takes into account the large ratio of dead load to live load.
 - Kuat V : Combination of loading that combines the normal operation of the bridge and wind loads of 90 - 126 km/hour.
 - Ekstrem I : The combination of earthquake loading where the importance of the bridge affects the live load factor EQ when the earthquake happened.
5. Prestress Analysis
Calculate initial condition of prestressed concrete (load transfer) due to material property. Furthermore, determine strand type aimed to obtain amount of tendon from initial condition, then loss prestressed is calculated.

6. Modelling using structural analysis Program

In this step, modelling was used SAP 2000 program to determine the period of the vibrating structure and internal forces working on the structure.

7. Structural performance control.
Structural performance control due to load combination, deflection, and momen ultimate.
8. Comparison Result
The comparison results on the PC-I girder and PC-U girder structures are obtained after controlling the two structures when given the same load so that the forces that occur are in the form of maximum moment, maximum shear and axial.
9. Conclusions.
The conclusions are the results of a comparison of the forces or reactions that occur in the structural elements, the behavior of PC-I and PC-U structural elements and the impact of using PC-I girder and PC-U Girder on the flyover.

3. Results and Discussions

3.1 Cross section area of the beam

There is any differences between PC-I Girder and PC-U Girder due to section area, the difference can be described in Figure 4 below.

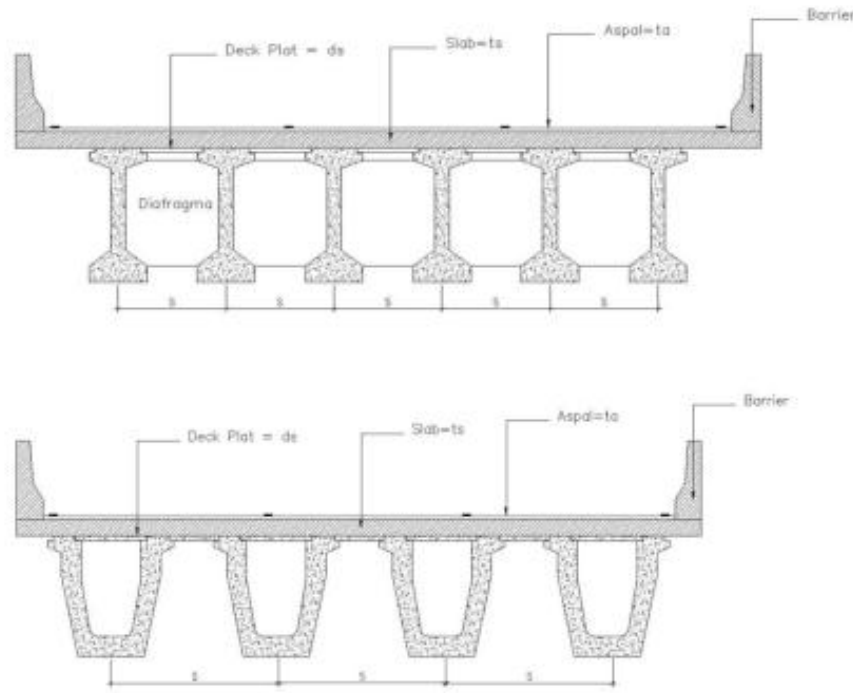

Source : Processed Data (2022).

Figure 4. Cross Section of PC-I Girder and PC-U Girder

Based on the calculation of the section area, the PC-I girder obtained a value of 0.850 m² for the area of one girder, while the PC-U girder obtained an area of 1.294 m² for the area of one girder. Section area of the PC-I and PC-U is shown in the following Table 2.

Table 2. Comparison of cross section PC-I Girder and PC-U Girder

PC-I			PC-U		
Area Section (m ²)	Amount of beam	Total of Area (m ²)	Area Section (m ²)	Amount of beam	Total of Area (m ²)
0,85	6	5,1	1,294	4	5,176

Source : Processed Data (2022).

From the Table 2, it can be seen the value of area section PC-I (5,176 m²) is larger than PC-U (5,100 m²).

3.2 Prestressed Beam Reaction

Then, the next stage is to conduct internal force between PC-I and PC-U Girder which is used to compare Moment and Shear Forces both of PC-I and PC-U. Using SAP 2000 software, Moment and Shear Force are obtained in Table 3 as follows.

Table 3. Moment and Shear Forces

No.	Load Combination	PC-I Girder		PC-U Girder	
		Moment (Ton.m)	Shear (Ton)	Moment (Ton.m)	Shear (Ton)
1	Kuat 1T	1447.49	123.726	1743,006	153.267
2	Kuat 1D	1541.979	144.771	2252,599	209,52
3	Kuat 2T	1422.796	134.95	2053,914	193,156
4	Kuat 2D	1422.796	134.95	2053,914	193,156
5	Kuat 3	967.251	96.735	1262,758	126,276
6	Kuat 4	919.569	91.967	1215,077	121,508
7	Kuat 5	933.192	93.329	1228,700	122,870
8	Service 1T	958.491	84.171	1150,883	103,403
9	Service 1D	1010.980	95.863	1433,990	134,659
10	Service 2T	1036.261	88.443	1228,654	107,674
11	Service 2D	1104.497	103.642	1596,693	148,307
12	Service 3T	889.614	79.621	1082,007	98,852
13	Service 3D	931.606	88.974	1308,492	123,857
14	Service 4	654.979	65.506	847,372	84,737

Source : Processed Data (2022).

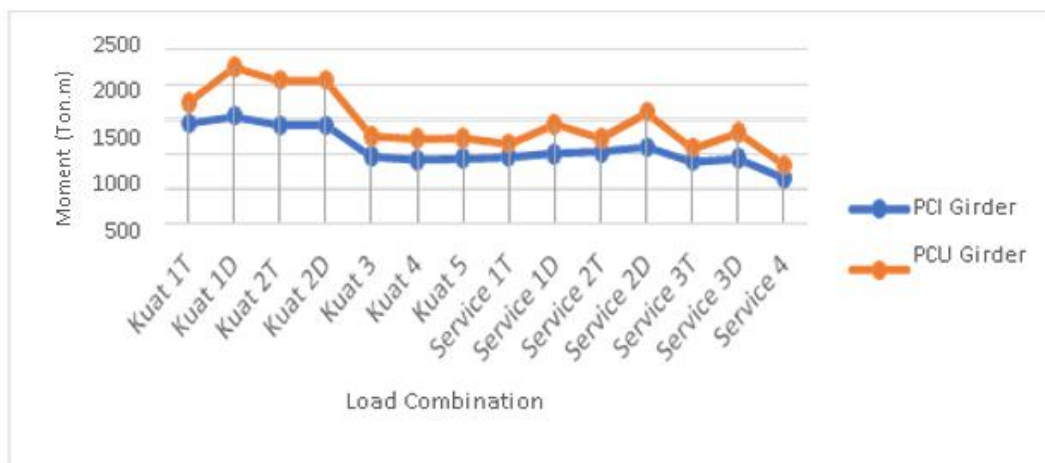

Source : Processed Data (2022).

Figure 5. Maximum moment due to load combination

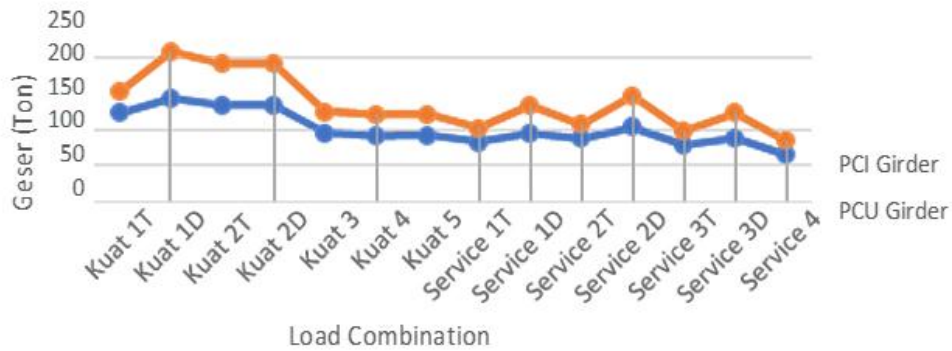

Source : Processed Data (2022).

Figure 6. Maximum Shear Force due to load combination

Based on Table 3, Figure 5, and Figure 6, It can be seen that Maximum Momen and Shear force value occurred in both PC-I and PC-U Girder. It is caused by load combination Kuat 1D. PC-I It shows Maximum Moment PC-I Girder value = 1541,979 Ton.M and PC-U Girder value = 2252,99 Ton.m. Meanwhile Maximum Shear force PC-I value = 144,771 Ton and PC-U value = 209,52 Ton.

3.3 Strand requirements for each girder

Using of strand comparison is made to determine the efficiency in the number of requirements for each beam. In PC-I Girder, 60 Strands are needed with 6 girders so that 360 strands are needed, while in PC-U Girders 128 Strands are needed with 4 girders, so 512 strands are needed.

$$\text{Percentage Difference (\%)} = \frac{\text{difference between PC-I and PC-U}}{\text{PC-U}} \times 100 \% = \frac{512-360}{360} \times 100\% = 42,22\%$$

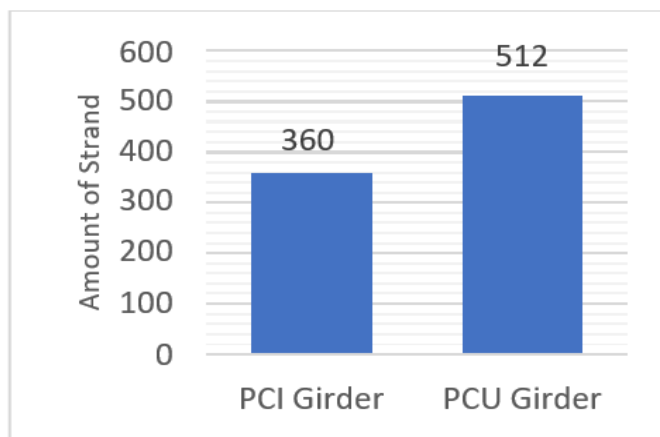

Source : Processed Data (2022).

Figure 7. Strand requirements comparison

From the figure 7, it can be concluded that the need for strand in PC-U Girder requires more strand than of PC-I Girder, Berdasarkan grafik di atas, dapat disimpulkan bahwa PC-U Girder membutuhkan banyak strand, the percentage difference is 42,22%.

3.4 Loss of Prestressed

Loss of prestressing force is force reduction that occurs in the tendon when loading is carried out, it is necessary to analyze the loss of prestressing force. So in this study the loss of prestressing force on the PC-I Girder and PC-U Girder was compared.

Table 4. Percentage of Loss Prestressed PC-I and PC-U Girder

No.	Loss of Prestressed	PC-I Girder (Ton)	PC-I Girder (%)	PC-U Girder (Ton)	PC-U Girder (%)
1	Jacking Force	785,4	70%	1675,5	
2	Anchorage	761,8	68%	1625,2	70%
3	Friction Elastic	698,6	62%	1466,9	62%
4	Shortening Relaxation of Steel	633,8	56%	1323,9	55%
	Total of Loss Prestressed	618,2	21%	1274,1	24%

Source : Processed Data (2022).

From the Table 4, it shows that loss of prestressed that occur in PC-U Girder is higher (percentage of loss of prestressed=24%) than PC-I ((percentage of loss of prestressed=21%).

4. Conclusion and Suggestion

4.1 Conclusion

Based on the analysis of the calculation results that have been carried out and using the SAP 2000 software, conclusions can be drawn including :

1. Due to calculation of floor slab reinforcement, the difference in the ratio of reinforcement in the flyover model using prestressed beams PC-I Girder and PC-U Girder with each ratio value for the support area is 0.00440 and the field area is 0.00387 for the model with using PC-I Girder. Meanwhile, for the model using PC-U Girder, the reinforcement ratio in the support area is 0.00412 and the field area is 0.00363. So that the ratio required for the floor slab with the flyover model using PC-I Girder prestressed beams is higher, this is caused the PC-I girder model is different from PC-U, in the PC-U model the area of the slab that is not supported is more visible. smaller than PC-I so that it affects the ratio of floor slab reinforcement.
2. Based on calculation of the area of the PC-I prestressed beam, an area of 5,100 m² with 6 beams is obtained, while the PC-U prestressed beam has an area of 5,176 m² with a total of 4 beams, so that the area of the flyover with the PC-U girder prestressed beam model 3.45% wider than PC-I.
3. The use of Strands on PC-I Girder beams requires as many as 60 Strands for 1 prestressed beam so that the bridge structure with PC-I Girder prestressed beams requires 360 strands while the beam PC-U Girder prestressing requires 128 for 1 beam so it requires 512 strands for a bridge structure with PC-U girder prestressing beams. So that the percentage ratio of 42.22% is obtained
4. From the SAP 2000 output, the maximum moment and maximum shear reaction values for PC-I Girder prestressed beams are 1541,979 Ton.m and 144,771 Tons caused by a combination of 1D Strong load, while on PC-U Girder the maximum moment and maximum shear values are 2252.599 Ton.m and 209.52 Ton due to the same load combination so that the moment and shear produced by the PC-U Girder are 46.08% greater for the moment and 44.725% for the shear than the load on the PC-I Girder. Based on the results of the SAP 2000 output, the maximum moment reaction value for the pillars with the PC-I Girder prestressed

beam model is 440.874 Ton.m while the PC-U Girder prestressed beam model is 443.256 Ton.m each caused by a combination of 1D Strong load. so that in the use of PC-U there is a difference of 0.53% greater than the pillars in the use of PC-I Girder. The maximum shear value for the flyover model using PC-I Girder prestressed beams is 6,3788 tons caused by the combination of Strength 5, while for the flyover model using PC-U girder the value is 4,394 Tons obtained from the 1D Strength combination. so that in the use of PC-I there is a ratio of 45.17% greater than the PC-U girder.

5. In the result loss of prestressed beam for PCI Girder, the prestressing force loss is 21% while for PC-U Girder by 24%. This result was caused PC-U Girder need more strand than PC-I Girder.

4.1 Suggestion

Due to better research result in further search, authors suggest the following:

1. Analysis of the calculation of prestressing beams, understanding and accuracy are needed in order to obtain more accurate results.
2. It is necessary to understand the SAP 2000 V14.2.5 auxiliary program. Especially when controlling the structure (behavior and internal forces) so that the resulting output is more accurate.

References

- [1] T. A. Aprianto and K. H. Putra, "ANALISIS FORECASTING METHOD PERTUMBUHAN LALU LINTAS PADA RUAS JALAN ACHMAD YANI SURABAYA," pp. 54–60.
- [2] I. Hidayat, "ANALISIS PERHITUNGAN JEMBATAN GELAGAR I PADA JEMBATAN JALAN RAYA DAN JEMBATAN KERETA API Metode Perhitungan," no. 9, pp. 517–528, 1921.
- [3] B. P. Putra *et al.*, "STUDI PERBANDINGAN PENGGUNAAN PCU GIRDER DAN PCI GIRDER," vol. XXII, no. 1, 2017.
- [4] N. B. Tiburzi, T. Drimalas, and K. J. Folliard, "Cement and Concrete Research Evaluation of precast bridge girder cracking : The role of volume change," *Cem. Concr. Res.*, vol. 101, no. September, pp. 55–67, 2017, doi: 10.1016/j.cemconres.2017.08.024.
- [5] M. Alawneh and M. K. Tadros, "Optimized ultra-high-performance concrete horizontally curved bridge superstructure," no. April, 2022.
- [6] A. P. Astuti, T. P. Artiningsih, and I. Pendahuluan, "ANALISIS PERBANDINGAN PCI GIRDER TERHADAP PCU GIRDER EXISTING," pp. 1–7.
- [7] S. N. Indonesia and B. S. Nasional, "Pembebanan untuk jembatan," 2016.
- [8] G. J. Perkotaan, "Geometri Jalan Perkotaan," 2004.
- [9] S. T. Side, "ANALYSIS COMPARISON LOSS OF PRESSTRES," vol. XII, no. 1, pp. 1–7, 2020.
- [10] M. N. Sholeh and U. Diponegoro, "Design of Sustainable Construction Through Value Engineering of an Design of Sustainable Construction Through Value Engineering of an Automated People Mover System Project," no. April, 2020, doi: 10.1088/1755-1315/448/1/012060.
- [11] H. Prayuda *et al.*, "Pengaruh Modifikasi Penampang pada I - Girder dan Box Girder Beton Prategang terhadap Kekakuan dan Lendutan," vol. 27, no. 1, pp. 97–106, 2021.

- [12] J. Zhang, Y. Jing, P. Li, W. Han, N. Zhang, and Y. Zhou, “Experimental and Numerical Investigation on the Ultimate Vertical Bearing Capacity of U-Shaped,” 2019.
- [13] J. Ilmiah, T. Sipil, P. N. Samarinda, J. T. Sipil, P. N. Samarinda, and K. Timur, “ANALISA DESAIN PC I GIRDER PADA SECTION OVERPASS,” vol. 13, no. 1, pp. 25–35, 2021.
- [14] B. Massicotte and N. Cordonni, “Design of precast prestressed SFRC T-girders for accelerated sustainable bridge construction 1 Introduction,” pp. 195–204.
- [15] I. Bridges *et al.*, “Evaluation of Cast-in-Place Splice Regions of Spliced,” no. 116, pp. 181–194, 2019, doi: 10.14359/51716804.
- [16] B. C. Jagtap and P. M. Shahezad, “Comparative Study of Prestressed Concrete Girder and Steel Plate Girder for Roadway Over Bridge,” vol. 2, no. 1, pp. 113–117, 2016.
- [17] S. Rana, R. Ahsan, and S. N. Ghani, “Design of prestressed concrete I-girder bridge superstructure using optimization algorithm,” pp. 978–984, 2010.
- [18] V. U. Misal, N. G. Gore, and P. J. Salunke, “Analysis and Design of Prestressed Concrete Girder,” no. 9, pp. 43–47, 2014.
- [19] I. Yamin and S. Zuraida, “Analisis Perbandingan Kehilangan Prategang Akibat Variasi Letak Tendon PC I Girder Jembatan Beton Prategang,” vol. 2, no. 2, pp. 34–42, 2020.
- [20] R. T--, “IcoT UST 2018 - Teknik Sipil UST IcoT UST 2018 - Teknik Sipil UST,” vol. 2016, no. 2008, pp. 31–34, 2016.